



VoIP Analysis

Manage, Monitor, and Maintain VoIP Communications
Across Enterprise Networks with Observer®

Obtain the detail and diagnostics necessary to solve today's VoIP problems.

Today's enterprise administrators face a multitude of VoIP management challenges. These challenges begin when first preparing for VoIP implementation, continue throughout VoIP deployment, and persist as VoIP traffic traverses across complex, heterogeneous network links.

Effective management of VoIP call quality requires hard data beyond subjective user assessments. Observer's VoIP Expert delivers the essential analysis required to manage, troubleshoot, and maintain the quality of VoIP communications. Regardless of whether you need management-level VoIP summaries or command-level details of a particular call, Observer delivers.

Use Observer's VoIP Analysis to . . .

- Focus on real, live traffic issues with over 70 VoIP metrics
- View quick summaries of overall VoIP status
- Drill down to specific connection details for faster troubleshooting
- Immediately identify quality issues with over 50 VoIP Expert events
- Measure call quality individually and in aggregate

From aggregate-level VoIP summaries...

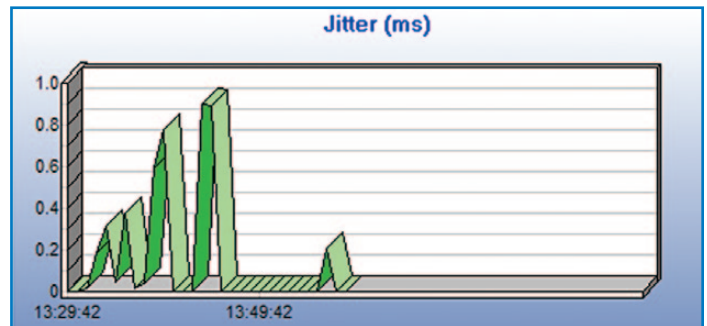

ID / Stream	Station 1 / Port	Station 2 / Port	Status
→ RTP	20012	33000	
1769786691-277	207.218.140.178		Closed
Zultys MX250 - "Dev4"	207.218.140.178	207.218.141.123	Closed
← SIP/SDP	5060	5060	
→ SIP/SDP	5060	5060	
Connection 3	207.218.141.123	207.218.141.125	Closed
← RTP	33000	33000	
→ RTP	33000	33000	
← RTCP	33001	33001	
→ RTCP	33001	33001	
1930103421-277	207.218.140.178		Closed
Zultys MX250 - "Dev4"	207.218.140.178	207.218.141.123	Closed

...to individual call detail records...

...to connection breakdowns.

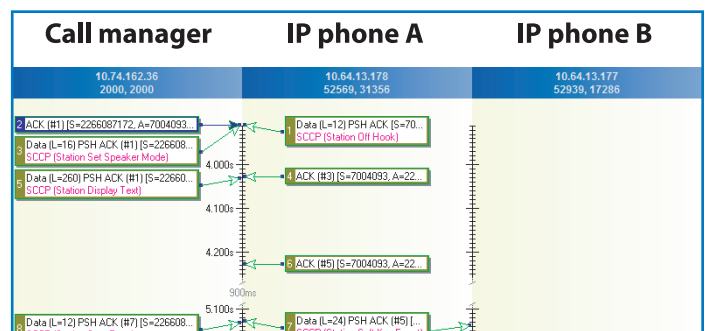



Monitor VoIP Communications In-Depth

Problems with VoIP audio quality are almost always the result of network delay, jitter, and packet loss, or some combination of these issues. Observer tracks network factors that affect quality, and reports call quality scores, which measure overall VoIP network health. Monitor aggregate statistics such as traffic summary, total number of VoIP packets, average jitter rates, and overall call quality. Or drill down into call detail records for individual information such as MOS/R-factor scores, QoS prioritization levels, call setup, duration, and teardown.

Convenient yet comprehensive summaries

- VoIP Traffic Summary
- Call Summary
- Voice Quality Scoring
- Precedence (QoS)
- Summary Graphs

“We just deployed VoIP on a remote site where our user expectation was high. But we had a great deal of technical problems—for example the sound would drop out. Observer helped us identify problem areas and helped us pinpoint the location to implement Quality of Service measures. With Observer, we ultimately improved the performance of VoIP on our network.”

Steve Phelan
The Carphone Warehouse Group

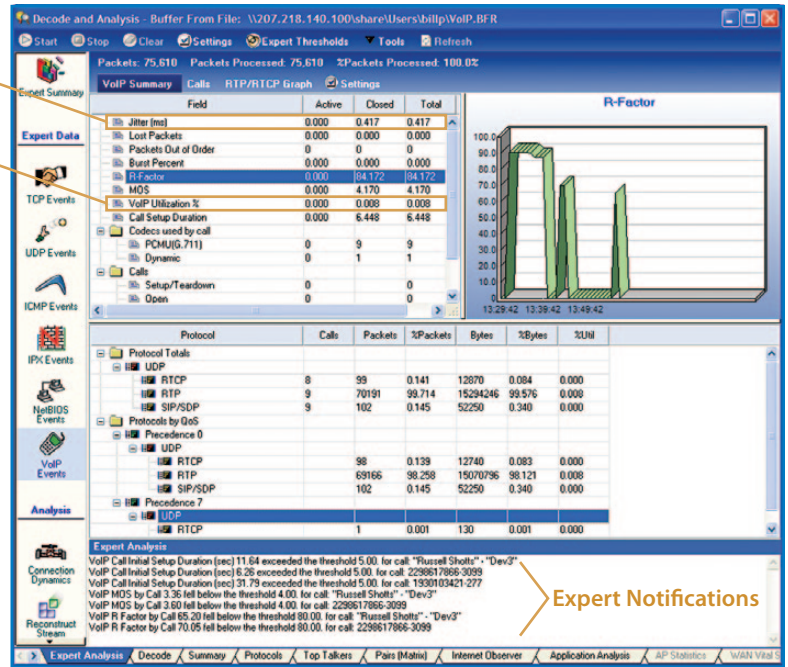

Aggregate Jitter
Total VoIP Utilization

Expert Notifications

VoIP Summary

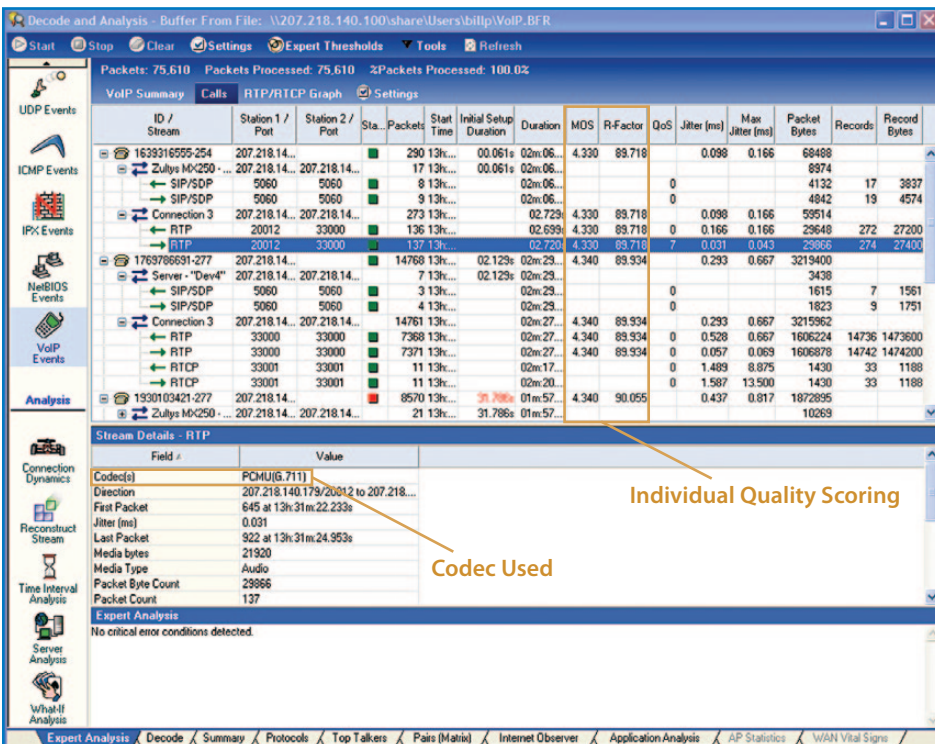

Detailed views with in-depth Call Detail Records

- Addresses
- Call status (open, closed, fail)
- Number of packets, packet bytes, packet loss
- Start time, initial setup duration, duration
- Current jitter, maximum jitter
- MOS, R-factor
- QoS per call
- Number of packets that arrive out of order
- Detailed analysis for packet loss and delay
- Gap density, average gap duration

Individual Quality Scoring

Codec Used

Call Detail Records

Quickly Solve VoIP Problems with VoIP Expert

Use Observer's Expert help to efficiently find the source of VoIP trouble. Observer includes over 50 event-based and threshold-based VoIP Experts.

Examples include:

- Alarms for unacceptable jitter level
- Lost packets
- Alterations in the QoS stream

Manage VoIP Audio Quality

The **Mean Opinion Score (MOS)** is an overall quality index that calculates how a typical user would rate audio quality given the current network conditions. Placing an alarm on this score is a good way to pro-actively manage overall VoIP quality: If MOS starts to fall below 3.5 (out of 5), further investigation might be necessary to determine why VoIP quality is suffering. These factors can be customized depending on the network's specific VoIP equipment and overall network characteristics. For example, VoIP quality on calls made from the factory floor over multiple hops may be scored differently than a call made within a small office setting.

Quality Score Impairment Factors include:

- Loudness rating
- Talker Echo rating
- Circuit noise
- Floor noise
- Room noise
- Coding / decoding delay

Maintaining Quality of Service

Observer's VoIP Expert recognizes and decodes the IP Type Of Service field precedence bit—a mechanism for prioritizing traffic for applications such as VoIP. **Quality of Service (QoS)** level is therefore reported by call, packet, and protocol. VoIP Expert also shows percentage of VoIP utilization as compared to the rest of network traffic, which is essential for planning network upgrades.

QoS Standards Recognized

- Default: RFC 1349, 1195, 1123, 791
- OSPF V2: RFC 1248, 1247
- DSCP: RFC 2474

View Conversational Streams in Detail

Observer's comprehensive call display details statistics for all of the data streams that comprises a VoIP call, including call setup communications, the actual voice conversation, and call teardown communications. Use this to monitor call ID and stream information including **gap density** (the rate of low-level packet loss), **burst density** (the rate of packet loss during bursts of packet loss), and other critical statistics.

VoIP Expert includes call ID and stream information such as:

- Number of packets
- Call setup
- Duration
- Teardown
- Lost packets
- Jitter
- Gap density
- Burst density

Stream By Stream

ID / Stream	Station 1 / Station Port	Status	Start Time	Initial Setup Duration	Duration	MOS	R-Factor	QoS	Packets Lost	Jitter (ms)	Burst Density	Gap Density	Average Burst Duration	Average Gap Duration
Call 14	10.74.162...		13h07m...	00:141s	01:94s									
Call 15	10.74.162...		13h07m...	04:812s	04:812s	4.090	81.709	0.000	0.241	0.000	0.000	0s	52.235s	
Jason Mauk... 20	10.64.131... 10.74.1...		13h07m...	00:208s	02m:14.562s				3					
Brett Messin...	10.64.131... 10.74.1...		13h07m...	00:208s	02m:14.395s				3					
Jason Mauk...	10.64.131... 10.64.1...		13h07m...	02m:10.657s	4:090	81.709	0.000	0.241	0.000	0.000	0.000	0s	52.235s	
Jason Mauk...	10.64.131... 10.74.1...		13h07m...	02m:10.657s	4:090	81.709	5	0.000	0.195	0.000	0.000	0s	52.272s	
Jason Mauk...	10.64.131... 10.74.1...		13h07m...	02m:10.657s	4:090	81.709	5	0.000	0.286	0.000	0.000	0s	52.288s	
Call 18	10.74.162...		13h07m...	00:141s	01:94s									
Connection 1	10.64.131... 10.74.1...		13h07m...	00:141s	01:94s									
Jason Mauk... 20	10.64.131... 10.74.1...		13h07m...	04:812s	02m:15.710s	4.380	91.694	0.000	0.241	0.000	0.000	0s	52.235s	
Brett Messin...	10.64.131... 10.74.1...		13h07m...	04:812s	02m:15.710s				3					
Jason Mauk...	10.64.131... 10.74.1...		13h07m...	00:208s	02m:14.562s				3					
Jason Mauk...	10.64.131... 10.74.1...		13h07m...	00:208s	02m:14.562s				3					
Jason Mauk...	10.64.131... 10.64.1...		13h07m...	02m:10.657s	4:380	91.694	0.000	0.241	0.000	0.000	0.000	0s	52.235s	

Comprehensive VoIP Call Display

"Our next big project is VoIP, and Observer's VoIP Analysis feature is going to assist us with implementation. Before, I wouldn't have known if our systems were prepared for VoIP deployment but now I have the confidence we can go forward. With Observer, I'm making more intelligent decisions about the future of our network."

Mesmak "Mark" Giorgis
Long Beach Transit

Troubleshoot Connection Problems

When VoIP users cannot obtain a dial tone, or if there is excessive delay in connecting to the other party's phone, examining a graphical display of how the call is progressing between the parties and the call manager may reveal the source of the communication breakdown.

Observer's VoIP Expert provides a Connection Dynamics display—a unique Observer feature for quickly identifying latency and delay. Simply right-click on any call or connection stream to determine which party is not responding or which party is responding slowly.

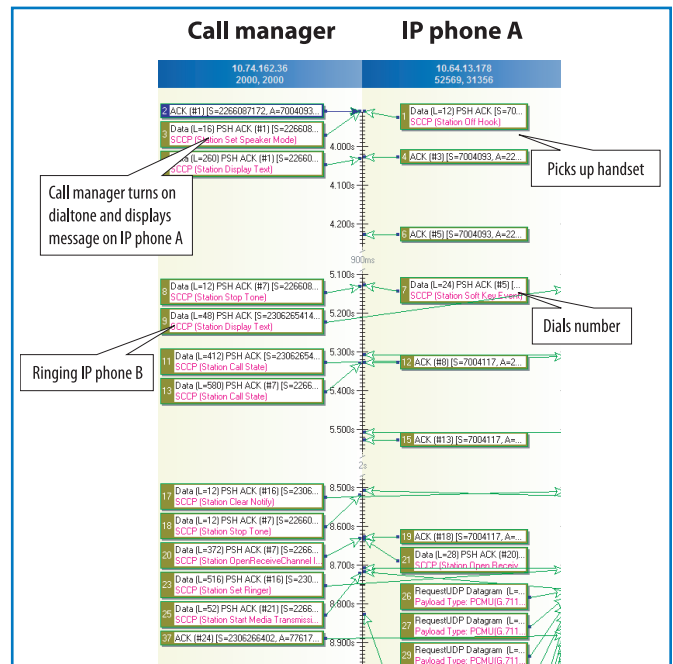

Connection Dynamics

Monitor VoWLAN

With the Network Instruments' Distributed Network Analysis (NI-DNA™) architecture, all of Observer's VoIP enhancements are automatically available across multiple topologies. For example, Observer's VoIP Expert has the capability to monitor VoIP traffic even over wireless networks.

Decode and Reconstruct Voice and Video Streams

Observer offers complete VoIP and video decodes, including H.323, Session Initiation Protocol (SIP), MGCP, and SCCP (Cisco "skinny"). Reconstruct streams into a .WAV or .AVI file for replay.

Compare VoIP to Network Performance

Could total network bandwidth affect jitter and delay? Observer's VoIP Expert charts jitter in each direction of a VoIP call and compares it to total bandwidth utilization. Use this information to determine if network load is affecting VoIP call quality.

"So far, Observer's VoIP capabilities have helped cut CI Travel's phone bill by about 25-30 percent."

Paul Ingram
CI Travel

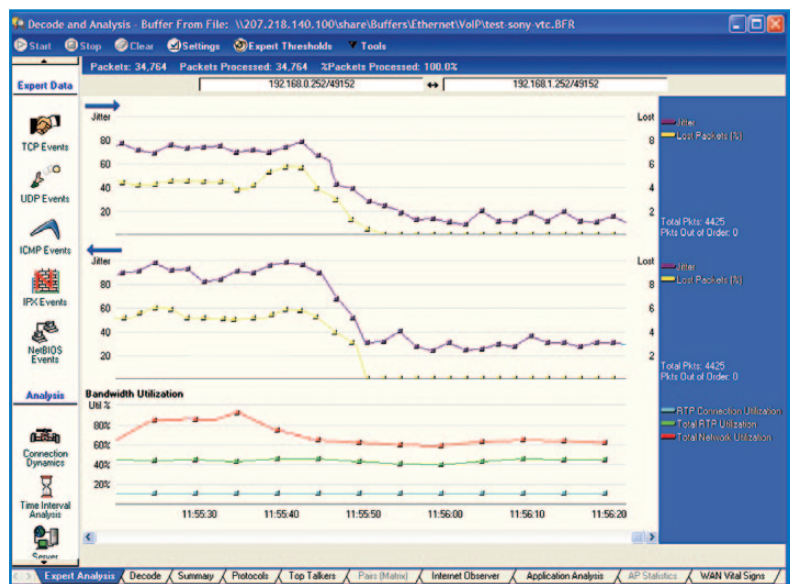

Call Mapping

Operative Software Products

7219 Kentwood Avenue • Los Angeles, CA 90045
telephone US only (866) 204-6289 or (310) 410-9350

www.operativesoft.com/html/observer.htm

